

Fast Querying in Database with Images by Using Multiresolution

Mitko Kostov, Mile Petkovski, Ilija Jolevski¹

Abstract – In this paper we present an algorithm for fast querying in database with images. It uses multiresolution technique, all the images are decomposed in few levels and the most important wavelet coefficients are used for calculation of pseudohash. When searching for an image-query in the database, pseudohash is calculated from the image-query and used in a simple sql select statement.

Keywords – Wavelets, multiresolution, database, images, query, pseudohash.

I. INTRODUCTION

Wavelet transforms have received significant attention recently from mathematicians, signal analysts and engineers as a new tool for feature extraction, signal and image compression, edge detection and denoising. Unlike the traditional Fourier techniques, wavelets are localized both in time and frequency domain. This feature makes them suitable for the analysis of nonstationary signals.

This paper considers a practical implementation of the wavelet transform for a fast searching in a database with images. Images are decomposed in a few levels. Our algorithm calculates pseudohash information from images wavelet coefficients at a low-resolution level and stores such information in a database. When searching for an image-query in the database, pseudohash is calculated from the image-query and used in a simple sql statement to select images-candidates from the database that match some defined criteria.

The paper is organized as follows. The wavelet theory is summarized in Section 2. Section 3 presents the algorithm for fast querying in a database with images. The experimental results are presented in Section 4. Section 5 concludes the paper.

II. WAVELET THEORY

The Discrete Wavelet Transform (DWT) decomposes a signal into a set of orthogonal components describing the signal variation across the scale [1]. The orthogonal components are generated by dilations and translations of a prototype function ψ , called mother wavelet.

In analogy with other function expansions, a function f is presented for each discrete coordinate t as a sum of a wavelet expansion up to certain scale J plus a residual term, that is:

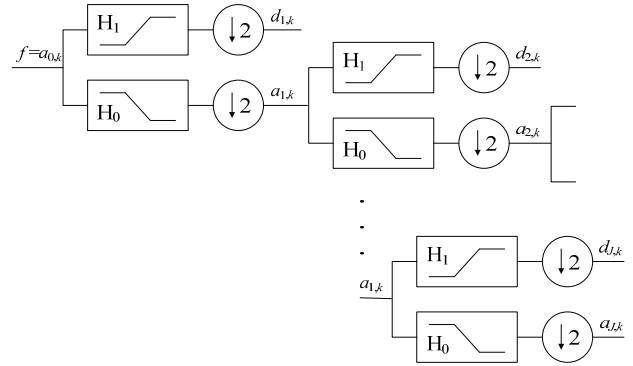

Fig. 1. Discrete wavelet transform tree.

$$f(t) = \sum_{j=1}^J \sum_{k=1}^{2^{-j}M} d_{jk} \psi_{jk}(t) + \sum_{k=1}^{2^{-J}M} a_{Jk} \phi_{Jk}(t) \quad (1)$$

where ψ_{jk} and ϕ_{jk} denote wavelet and scaling function, respectively, the indexes j and k are for dilatation and translation, and a_{jk} and d_{jk} are approximation and detail coefficients.

Wavelet decompositions and multiresolution concepts are closely related to filter bank theory. For this reason, it is helpful to view the scaling and wavelet function as a low pass and high pass filters, \mathbf{H}_0 and \mathbf{H}_1 , respectively. The wavelet transform is applied to low pass results (approximations) as it is illustrated in Fig. 1.

The most popular form of conventional wavelet-based signal filtering [1], can be expressed by:

$$\{\mathbf{A}^{(k)}, \mathbf{D}^{(1)}, \mathbf{D}^{(2)}, \dots, \mathbf{D}^{(k)}\} = \text{DWT}(\mathbf{s}),$$

$$\mathbf{s}^* = \text{IDWT}(f(\mathbf{A}^{(k)}, \mathbf{h}^{(1)} \cdot \mathbf{D}^{(1)}, \mathbf{h}^{(2)} \cdot \mathbf{D}^{(2)}, \dots, \mathbf{h}^{(k)} \cdot \mathbf{D}^{(k)})) \quad (2)$$

where \mathbf{s} is input signal, \mathbf{s}^* is filtered signal, $\mathbf{A}^{(k)}$ and $\mathbf{D}^{(k)}$ are approximation and detail coefficients at level k , respectively, f is a function of the modified detail and approximation coefficients, \cdot is element-by-element multiplying and

$$\mathbf{h}^{(k)} = [h_1^{(k)}, h_2^{(k)}, \dots, h_j^{(k)}]^T \quad (3)$$

are weighting coefficients of the corresponding detail coefficients at level k .

In case of conventional hard threshold filtering the weighting coefficients are

¹Mitko Kostov, Mile Petkovski and Ilija Jolevski are with the Faculty of Technical Sciences, I.L.Ribar bb, 7000 Bitola, Macedonia, E-mails: mitko.kostov@uklo.edu.mk, mile.petkovski@uklo.edu.mk, ilija.jolevski@uklo.edu.mk.

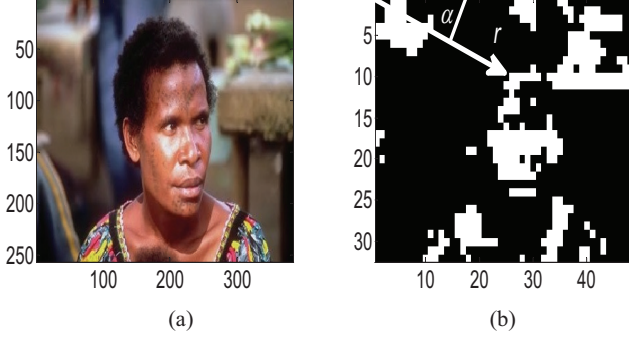

Fig. 2. (a) Image with resolution 384x256; (b) The most important wavelet approximation coefficients at level 3, resolution 48x32 (calculated with haar wavelet).

$$h_j^{(k)}(hard) = \begin{cases} 1, & \text{if } |D_j^{(k)}| > \tau^{(k)} \\ 0, & \text{otherwise} \end{cases}, \quad (4)$$

while for the soft threshold filtering they are

$$h_j^{(k)}(soft) = \begin{cases} 1 - \frac{\tau^{(k)} \operatorname{sgn}(D_j^{(k)})}{|D_j^{(k)}|}, & \text{if } |D_j^{(k)}| > \tau^{(k)} \\ 0, & \text{otherwise} \end{cases}, \quad (5)$$

where $\tau^{(k)}$ is user specified threshold for the k -th level details.

III. THE ALGORITHM

A. Basic Algorithm

The main idea is to search for a particular image-query in a large database with images and to select a few images as candidates. The images-candidates would be considered visually if some of them match the image-query.

Our database keeps pseudohash information for a large number of images. The pseudohash is calculated from the most important wavelet coefficients from a low-resolution level. Namely, the wavelet transform tends to concentrate the energy of a signal into a small number of coefficients, while a large number of coefficients have small energy. By applying a threshold given with (4) the most important wavelet coefficients are selected.

For the purpose of calculating the pseudohash, RGB images are converted to YCbCr colour space, where Y is the luminance (intensity) component and Cb (blue chrominance) and Cr (red chrominance) are the blue-difference and red-difference chroma components, respectively. The Y components are taken into consideration and wavelet transform is applied. After filtering the wavelet approximation coefficients obtained at certain low-resolution level, the most

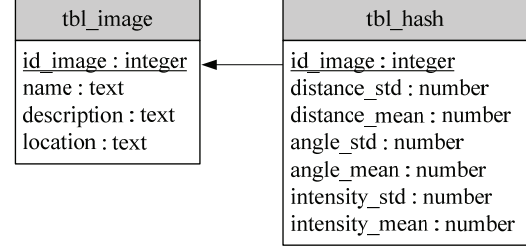

Fig. 3. Relations schema for the database with images.

important coefficients are selected. For these coefficients, three variables are defined: distance, angle and intensity, as it is illustrated in Fig. 2. An image with resolution 48x32 is shown in Fig. 2a and the most important wavelet approximation coefficients calculated with haar wavelet at level 3, are shown in Fig. 2b. For the three variables (distance, angle and intensity) both mean value and standard deviation are calculated and they compose the pseudohash information. Hence, an image pseudohash is consisted from six values: mean value and standard deviation for distance, angle and intensity of the non-zero pixels.

A database that keeps pseudohash information for the images contains a few relations with their schemas given in Fig. 3. In the relation `tbl_image`, the attribute `id_image` is the primary key. This relation contains description of the images: name, description and location (if the images are picture files in the file system). The relation `tbl_hash` contains pseudohash information for each image. The primary key, `id_image`, at the same time is foreign key that takes its values from the primary key of the relation `tbl_image`.

B. Extension

The algorithm is extended to search for circularly shifted images by involving Fourier transform, which is time/space invariant. Instead of calculating the wavelet coefficients from the Y component of the original images, the Fourier transform is applied to the Y components of all the images which eliminates the space information, then magnitudes of the Fourier coefficients are calculated, and at the end the inverse Fourier transform is applied. These modified images are used to calculate wavelet coefficients and pseudohash information as it is described in the basic algorithm.

When a database with schema shown in Fig. 3 is created and contains images pseudohash information, the process of querying an image can be summarized with the block-diagram shown in Fig. 4.

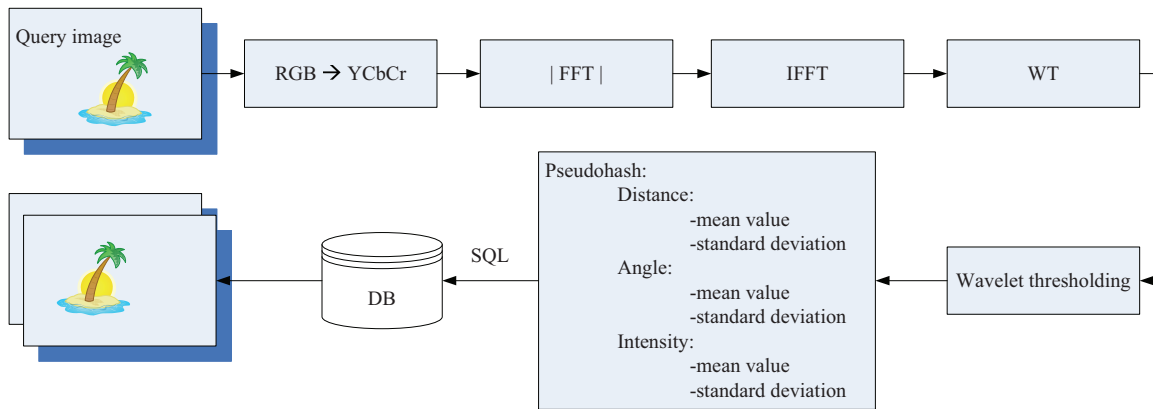

Fig. 4. Block diagram of querying with the proposed algorithm.



Fig. 5. Part of the database with 1000 images used for experiments.

IV. EXPERIMENTAL RESULTS

In this Section, our experimental results are explained. The experiments for fast searching are made with 1000 images which pseudohash information are stored in a Microsoft Access 2007 database with schema given in Fig. 3. Some of these images are shown in Fig. 5. The database contains a lot of similar images with people, animals, landscapes, objects,

etc. The database does not contain the images themselves; the images are picture files in the file system.

All these images are converted in YCbCr colour space, and the Fourier transform is applied over their Y components. Next, inverse Fourier transform is applied to the magnitudes of the Fourier coefficients. The obtained images from these successive operations of Fourier transform and inverse Fourier transform over the image from Fig. 2a are shown in Fig. 6a and Fig. 6b.

The haar wavelet transform in three levels is applied over

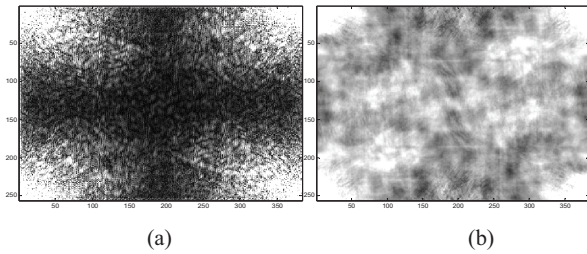

Fig. 6. (a) Magnitude of the Fourier transform over the image from Fig. 2a; (b) Inverse Fourier transform from Fig. 6a.



Fig. 7. (a) Circularly shifted version of the image from Fig. 2a; (b) Image with missing pixels.

the images obtained with inverse Fourier transform. The most important 20% pixels from the wavelet approximation coefficients at the third level are kept (Fig. 2b). It can be noticed that resolution of the wavelet coefficients at this level is 48×32 , which means that only a few coefficients are taken into consideration for the calculation the pseudohash. For the image in Fig. 2, the number of non-zero pixels after applying wavelet threshold is only 307. These coefficients are normalized so the maximum intensity is 255.

For the selected wavelet coefficients, mean value and standard deviation are calculated for the variables defined with distance, angle and intensity and they are stored in the relation `tbl_hash` (Fig. 3).

Table I shows pseudohash data for a part of the images from our database. The all attributes domains are integer in order to save space. The value of the attribute `id_image` for the image from Fig. 2 is 1.

In the querying process, the same algorithm is applied over an image-query and its pseudohash data is calculated according to the block-diagram from Fig. 4. A simple SQL SELECT statement is used to select the image from the database which pseudohash values corresponds to pseudohash data calculated from the image-query.

In addition, if the image-query is a circularly shifted version of an image in the database (Fig. 7a), it has the same pseudohash data as the the original image due to the using of the Fourier transform. Moreover, if the image-query misses some pixels or parts of the image-query miss as it is shown in Fig. 7b, its pseudohash data differs slightly from the pseudohash of the original. The original image from the database still can be selected by loosening the criterion in the

TABLE I
PSEUDOHASH DATA FOR A PART OF THE IMAGES IN THE
DATABASE

id_image	dist_std	dist_mean	ang_std	ang_mean	int_std	int_mean
0	16	32	27	50	24	11
1	14	33	28	39	22	10
2	15	33	28	37	21	9
3	16	32	24	57	26	12
4	14	32	25	33	25	11
5	17	33	28	41	22	10
6	15	33	27	39	19	8
7	17	32	27	36	22	9
8	18	33	30	44	24	11
9	14	32	26	39	20	8
10	15	31	24	35	22	10
11	15	33	29	53	24	11
12	17	33	27	39	21	9
13	15	32	28	48	19	8
14	17	32	28	38	28	13
15	18	33	30	44	23	10

sql statement and involving the operator 'between' in the 'where' clause to select a range of data between two values. The calculated pseudohash data for the image from Fig. 7b is (- 13 33 28 39 22 10), what is very similar to the pseudohash for the image with `id_image=1` (Fig. 2). The missing pixels in the image in Fig. 7b are not estimated.

V. CONCLUSION

In this paper we propose an algorithm for fast querying in database with images. The wavelet transform is exploited in order to select the most important wavelet coefficients. The most important wavelet coefficients are used to calculate pseudohash information. Pseudohash for a big number of images is stored in a database.

The algorithm is applied to an image-query and on the basis of calculated pseudohash, images-candidates from the database are selected.

Our future work will be focused on extending the algorithm for searching when the image-query is blurred or rotated, or it is manually drawn picture, a low-resolution image from a scanner or video camera.

REFERENCES

- [1] G. Strang and T. Nguyen, *Wavelets and Filter Banks*. Wellesley-Cambridge Press, 1996.
- [2] P. P. Vaidyanathan, *Multirate Systems and Filter Banks*, Prentice – Hall, 1992.
- [3] D. L. Donoho, "Wavelet Thresholding and W.V.D.: A 10-minute Tour", *Int. Conf. on Wavelets and Applications*, Toulouse, France, June 1992.
- [4] C. E. Jacobs, A. Finkelstein, D. H. Salesin, "Fast multiresolution image querying", *SIGGRAPH '95 Proceedings of the 22nd annual conference on Computer graphics and interactive techniques*.